

Article number: 20652014

Description: E+G Centring bore clamp GN 411.2-14.5-K

Measures

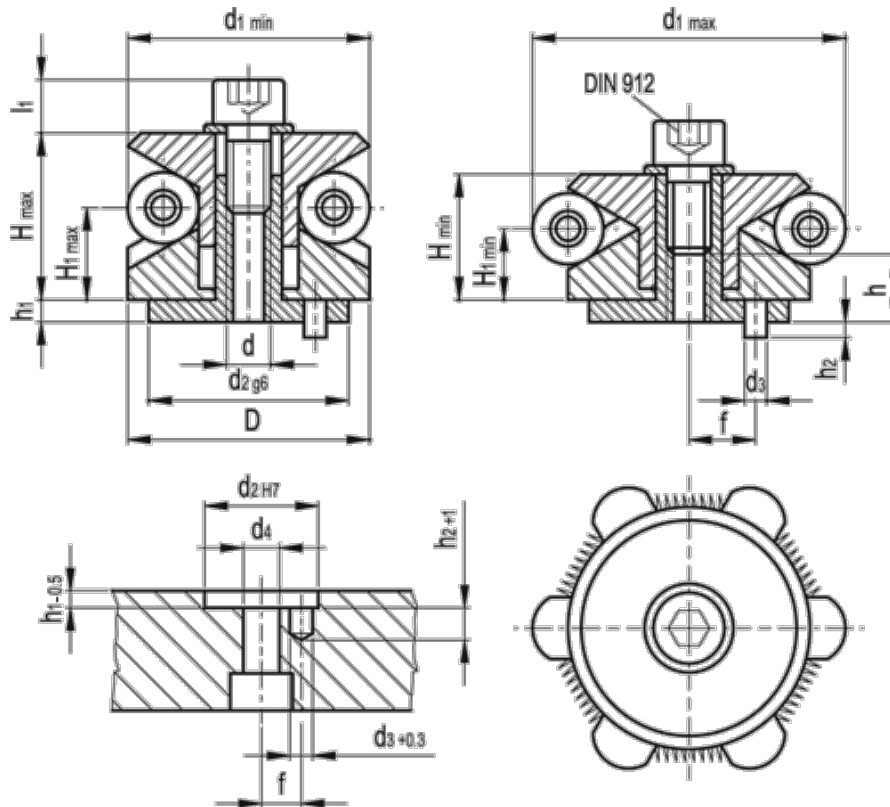

Clamping force (kN) = 3.50	d4 = 4.3	H min = 9.8
Clamping points = 3	f +/-0.1 = 4.5	l1 = 5.5
D = 14.5	h1 = 2.5	Weight (g) = 20
d = M4	H1 max = 7.1	
d1 max = 18.5	H1 min = 5.9	
d1 min = 14.5	h2 = 3.5	
d2 g6/H7 = 12	H max = 12.1	
d3 = 2.0	h min = 5	